



특징 (Character)

- 링크레버 타입의 3-JAW 각도개폐 방식
Angular type by link lever driving unit
- 원형, 구 등의 둥근 물체 핸들링에 적합
Suitable to grip for cylindrical & global workpiece
- 개폐검출 확인용 센서 부착가능
Magnetic sensor is available for open-close sensing



AF101
AF02
AF03
AF04P
AF105P
AF06
AF10
AF13
AF13C
AF14
AF15
AF316
AF17
AF117
AF19
AF24
AF26
AF28D
AF30
AF30L
AF30SP
AF40
AF46
AF56N
RAF56N
MF16

링크레버 방식 (Link lever type)

작동 방식 (Kinetics)

정교한 중심 파지를 위한
링크레버 방식
toggle system for centric
accurate gripping

구동부 (Drive)

복동식
double acting
pneumatic cylinder

조 (Jaws)

파지부
for gripping

몸체 (Body)

경질 처리된 경량의
알루미늄 합금
high-tensile aluminum body with
lightest possible because of
hard anodizing

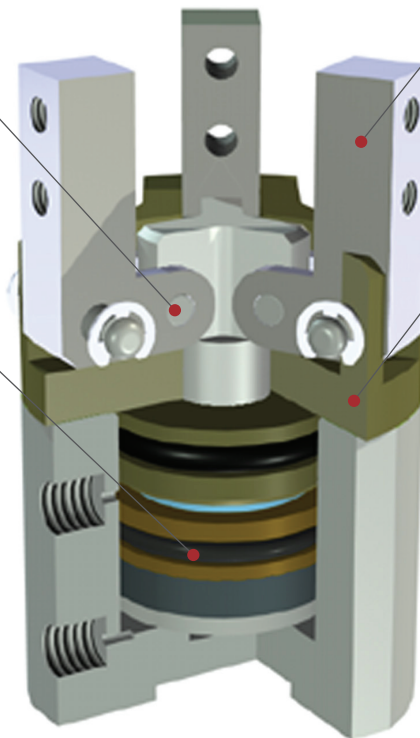

부품분해도 (Exploded view)

※ 본 분해도는 한 제품을 예시하였으므로 기종별로 차이가 있을 수 있습니다
 ※ This is exploded view illustrates a certain product only. The contents may vary by product models.

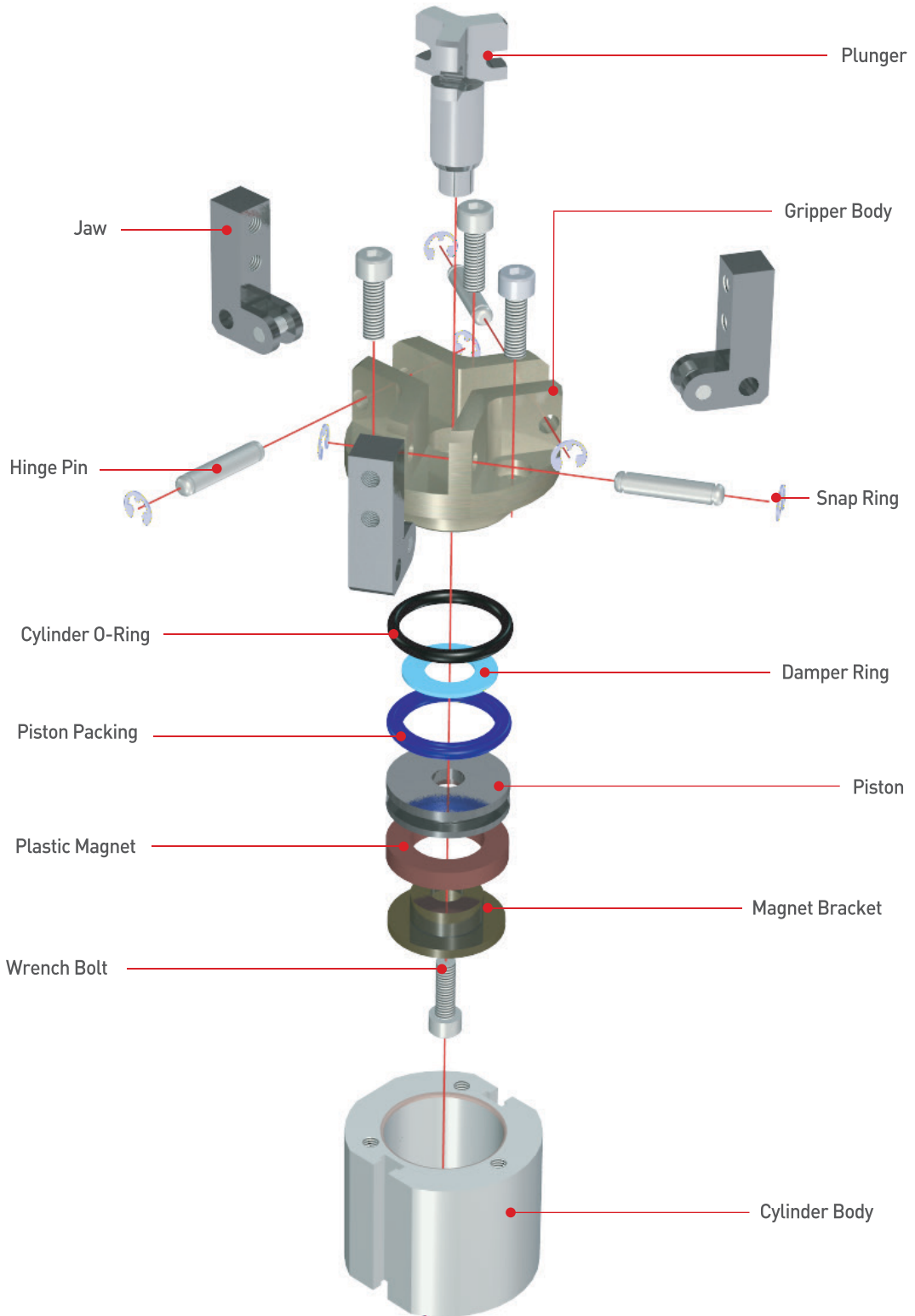

주문기호 (Ordering Code)

- AF101
- AF02
- AF03
- AF04P
- AF105P
- AF06**
- AF10
- AF13
- AF13C
- AF14
- AF15
- AF316
- AF17
- AF117
- AF19
- AF24
- AF26
- AF28D
- AF30
- AF30L
- AF30SP
- AF40
- AF46
- AF56N
- RAF56N
- MF16

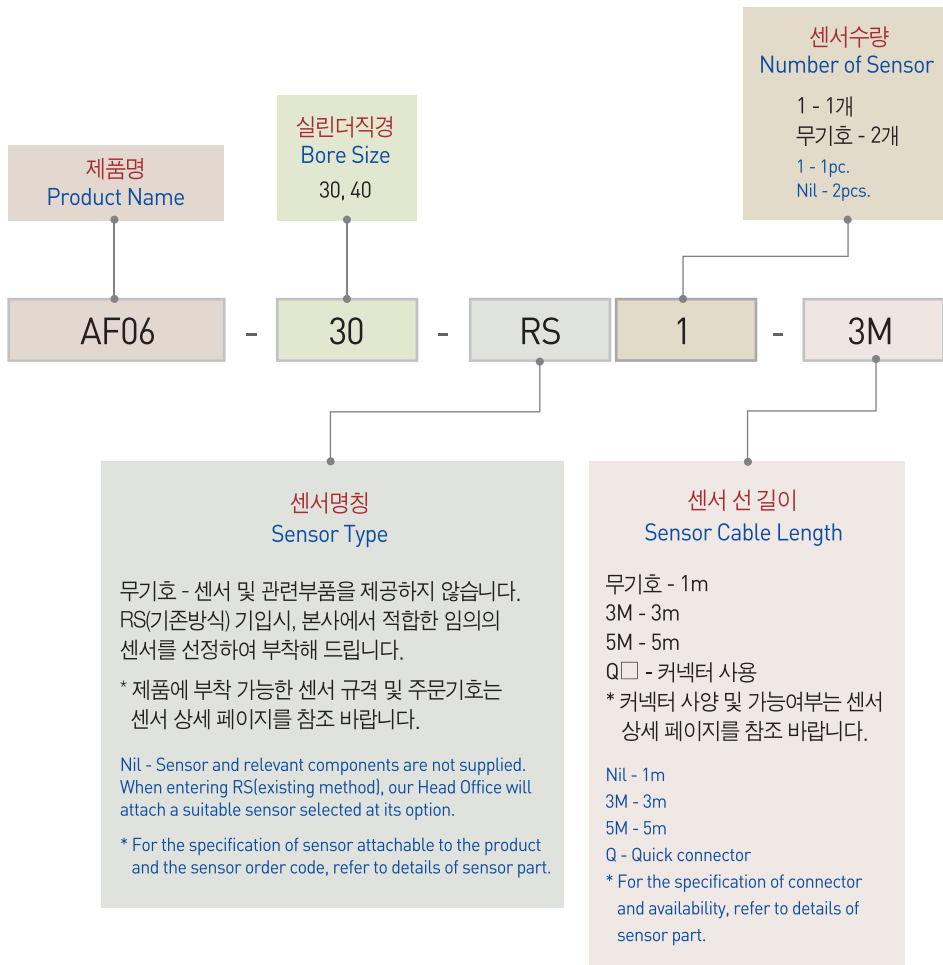

▣ 제품사양 (Specification)

P=공기압력(bar) , L=작용점까지의 거리(mm)
 P=Air Pressure(bar) , L=Exertion length(mm)

제품명칭 Products Name	AF06-30	AF06-40	단위 Unit
개폐범위 Stroke	-5 to 20	-5 to 20	degree
제품중량 Weight	0.39	0.64	kg
최대치구길이 Max. length attach	50	70	mm
배관접속구 Fitting size	PF(G) 1/8	PF(G) 1/8	
파지력 : 열림시 Gripping force : Open	9.81((5.65P-3)/0.1L)	9.81((10.4P-1.6)/0.1L)	N
파지력 : 닫힘시 Gripping force : Close	9.81((4.72P-9)/0.1L)	9.81((7.2P-8)/0.1L)	N
1사이클당 공기소모량 Air consumption per cycle	2.6	5.8	cm ³
닫힘시/열림시 시간 Closing / Opening time	0.01/0.01		sec
반복정밀도 Repeat accuracy	0.03		mm
연속사용회수 Continuation usage amount	30		cpm
사용압력 Operating pressure	3~7		bar
주위온도 Ambient temperature	-5 to 60		℃
윤활 Lubrication	불필요 Needless		

반복정밀도 : 연속 100회 작동후 측정치
 After 100 consecutive strokes to end positions

▣ 작용점에서의 파지력 (Gripping Force From a Point of Action)

범례(Legend) : —●— 7[bar] —■— 5[bar] —▲— 3[bar]

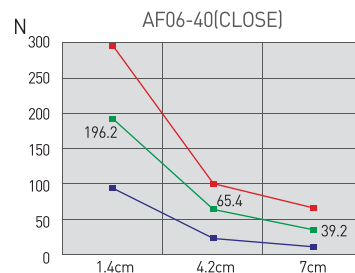
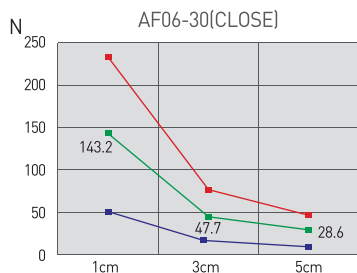
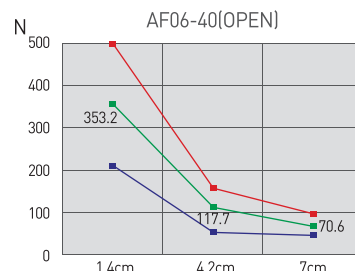
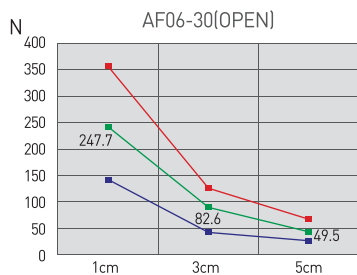

AF06-30

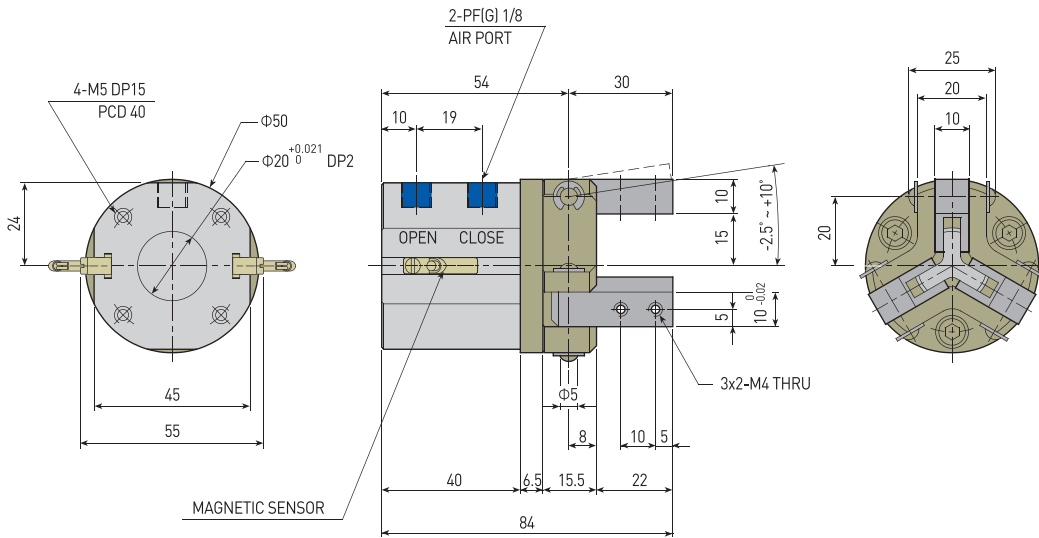

AF06-40

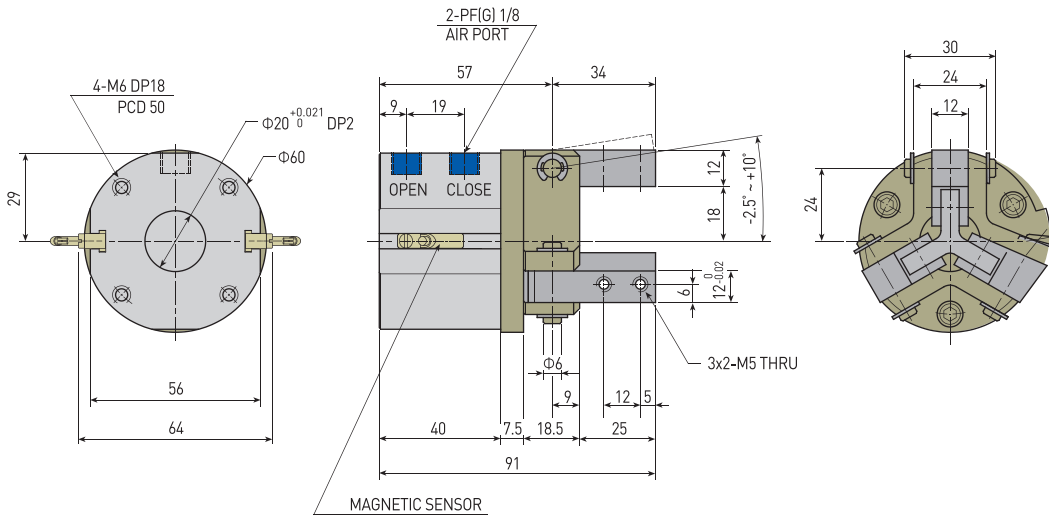

- AF101
- AF02
- AF03
- AF04P
- AF105P
- AF06**
- AF10
- AF13
- AF13C
- AF14
- AF15
- AF316
- AF17
- AF117
- AF19
- AF24
- AF26
- AF28D
- AF30
- AF30L
- AF30SP
- AF40
- AF46
- AF56N
- RAF56N
- MF16